

**PLAN VIEW**  
SCALE 1/4" = 1'-0"

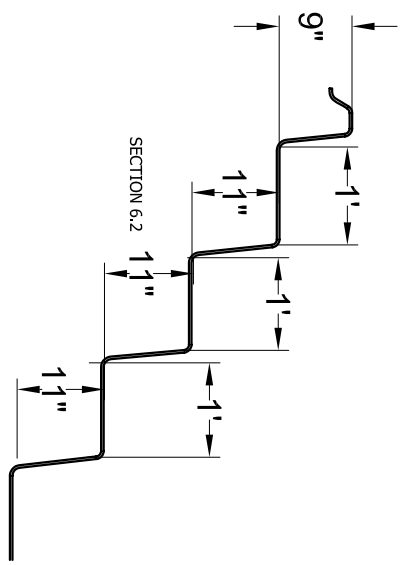

**STEP SECTION A-A**  
SCALE 1/2" = 1'-0"

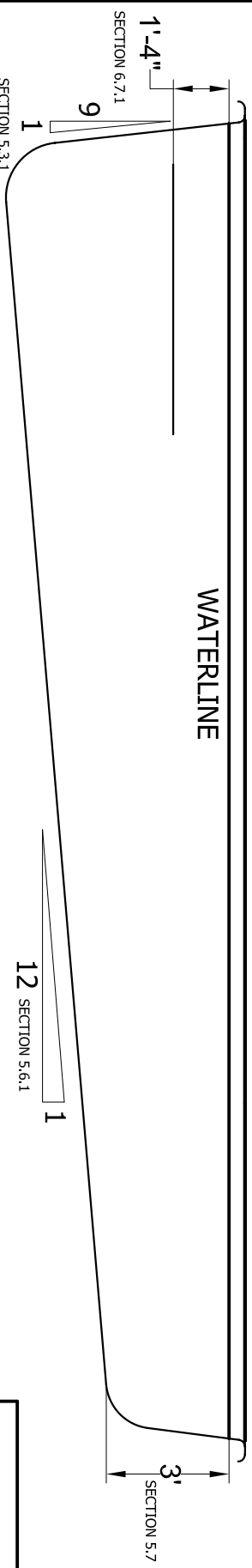

**ELEVATION**  
SCALE 1/4" = 1'-0"

AREA: 354 SQ. FT.  
PERIMETER: 80 FT  
VOLUME: 10300 GAL

AS PER SECTION 8.1, ALL SURFACES WITHIN THE POOL INTENDED TO PROVIDE FOOTING FOR BATHERS HAVE SLIP RESISTING SURFACES

<b>MANATEE 225 NSPI-5</b>	
SCALE AS NOTED	DATE 05-31-08
DRAWN BY KLB	REVISION 01